

HYDRIM[®] C51w

- **Operator's manual 1-29**
- **Mode d'emploi 30-59**



SciCan

A HIGHER STANDARD

Table of Contents

1. Introduction	1	6. Care and Maintenance	20
2. Important Information	2	6.1 Replacing the HIP Cleaning Solution ..	20
3. Disclaimers	3	6.2 Refilling the Water Softener Salt Reservoir	21
4. Installation Instructions	4	6.3 Cleaning the Hydrim C51w	22
5. Instructions for Use	6	6.4 Filter and Wash Arm Maintenance	22
5.1 Instrument Reprocessing Recommendations	6	7. Troubleshooting	23
5.2 Cycle Description Chart	7	8. Material Safety Data Sheet	25
5.3 Baskets and Accessories	8	9. Warranty	28
5.4 Activating the Hydrim C51w	9	10. Specifications	29
5.5 Interrupting / Aborting a Cycle	10		
5.6 Overview of the Hydrim C51w Menus	11		
5.7 User Menu	12		
5.8 Technician Menu	13		
5.9 Setup Menu	14		
5.10 Opening the Door in Case of Power Failure	19		
5.11 Printer / USB Setup	19		

Manufactured by:

SciCan Ltd.

1440 Don Mills Road,

Toronto ON M3B 3P9

CANADA

Phone: +001 -416 445-1600

Fax: +001-416- 445-2727

Toll free: 1-800-667-7733

For all service and repair inquiries:

Canada: 1-800-870-7777

United States: 1-800-572-1211

EU: +49-(0)821-278-93400

International: 1-416-445-1600

Email: techservice.ca@scican.com

HYDRIM and STATIM are registered trademarks of SciCan Ltd.

HIP is a trademark of SciCan Ltd.

All other trademarks referred to in this manual are the property of their respective owners.

1. Introduction

Thank you for selecting the Hydrim C51w instrument washer. The Hydrim complements the Statim autoclaves by quickly and hygienically preparing soiled instruments for sterilization. To ensure years of safe, trouble-free service, carefully review this Operator's Manual before operating the unit. The Hydrim C51w is suitable only for the applications listed in this manual. Using the Hydrim for other purposes may be dangerous. The manufacturer cannot be held responsible for damage caused by improper use.

Operational, maintenance and replacement instructions must be followed for the product to perform as designed. All trademarks referred to in this manual are the property of their respective owners. Contents of this manual are subject to change without notice to reflect changes and improvements to the Hydrim product.

The Hydrim C51w should only be installed and serviced by a qualified contractor as it is an Installation Category 2 device. Before connecting the unit, the installer should check that the voltage and frequency of the electrical supply correspond with the details in the installation instructions. The unit must only be plugged into a grounded outlet. Please note that this unit is completely isolated from the electrical supply only when it is unplugged or the circuit breaker is turned OFF. This must be done before any repair work is carried out.



The Hydrim C51w uses HIP™ Cleaning Solution exclusively. The unit will not perform as described if other detergents / cleaning products are used. Other detergents / cleaning products may damage the unit, the instruments, cause excessive foaming, and void the warranty. Do not use solvents in this unit. Do not allow small children or unauthorized personnel access to this unit or its controls.

2. Important Information

The following symbols appear in this book.



Caution, there is a potential hazard to the operator.



This situation may lead to a mechanical failure.



This is important information.

The following symbols appear on the touchscreen:



Used to stop the cycle



Forward Arrow – used to move to the next menu



Back Arrow – used to move to the previous menu



Up Arrow – used to adjust a value up, or to move between screens in a menu



Down Arrow – used to adjust a value down, or to move between screens in a menu



Unlock – used to unlock the door



Printer – used to obtain a print out, if the Hydrim has a printer



Used to clear the error history



Info menu – allows access to User, Setup and Technician menus.

3. Disclaimers

Do not permit any person other than authorized personnel to service, maintain or supply parts for your Hydrim C51w. SciCan shall not be liable for incidental, special or consequential damages caused by any maintenance or services performed on the Hydrim C51w by unauthorized personnel, or for the use of equipment or parts manufactured by a third party, including lost profits, any commercial loss, economic loss, or loss arising from personal injury.

Never remove the covers of the unit and never insert objects through holes or openings in the cabinetry. Doing so may damage the unit and/or pose a hazard to the operator. If the unit is used in a manner other than that specified, the protection provided by the equipment may be impaired. Avoid contact with eyes and mouth. Never lean on the open door. The unit may tip forward causing injury.

Always turn the unit **OFF** before adding softener salt, adding solutions or performing routine maintenance to the unit.

The owner shall not allow any personnel other than the trained and authorized personnel to operate the unit. For further information or questions about the Hydrim C51w, contact your authorized dealer or:

SciCan Ltd.

1440 Don Mills Road
Toronto ON M3B 3P9
CANADA
Phone: (416) 445-1600
Fax: (416) 445-2727
Toll free: 1-800-667-7733

EC Representative

BHT Hygienetechnik GmbH
Messerschmittstraße 11
86368 Gersthofen, Germany
Tel +49 (0) 821-2 78 93 400
Fax +49 (0) 821-78 93 401

SciCan Inc.

701 Technology Drive
Canonsburg, PA 15317
USA
Phone: (724) 820-1600
Fax: (724) 820-1479
Toll free: 1-800-572-1211

For all service and repair inquiries

EU +49- (0)821-278 93400
International 1-416- 445-1600
Canada: 1-800-870-7777
United States: 1-800-572-1211
Email: techservice.ca@scican.com

SciCan Medtech

Alpenstrasse 16
6300 Zug, Switzerland
Tel: +41(0) 41-727-7027
Fax: +41(0) 41-727-7029

4. Installation Instructions

To open the wash chamber door, pull the ring inside the chemical door.

Tools and supplies required for installation:

- Slot screwdriver
- Channellocks

Ensure that HIP Cleaning Solution (instrument wash chemical) is available. All other supplies are included with the Hydrim unit.

Specifications:

North America Voltage and Frequency: 208-240V, 60 Hz	Height: 475 mm/18.75"
International Voltage and Frequency: 220-240 V, 50 Hz	Width: 600 mm/23.75"
Rated load: 2 kW	Depth: 460 mm/18.25"
Circuit breaker: 10 A per phase	Depth with door open: 780 mm/30.75"
	Weight: 34 kg/75 lbs
	Running Noise: 60 dBA

Utility Hook-ups

Hose / Cord	Length / Diameter	Max. Distance Distance from inlet / drain	Water Pressure (optimal)*	Shut-off valve
Hot inlet	1.9 m / 6.2 ft. 3/4"	1.5 m / 5 ft.	1-10 bar 14.5 - 145 psi	Yes
Cold Inlet	1.9 m / 6.2 ft. 3/4"	1.5 m / 5 ft.	1-10 bar 14.5 - 145 psi	Yes
Drain	1.5 m / 5 ft. 3/4"	—	—	—
Electrical	1.8 m / 6 ft. AWG 18-3	—	—	—

* unit will function with water pressure down to 0.5 bar/ 7 psi.

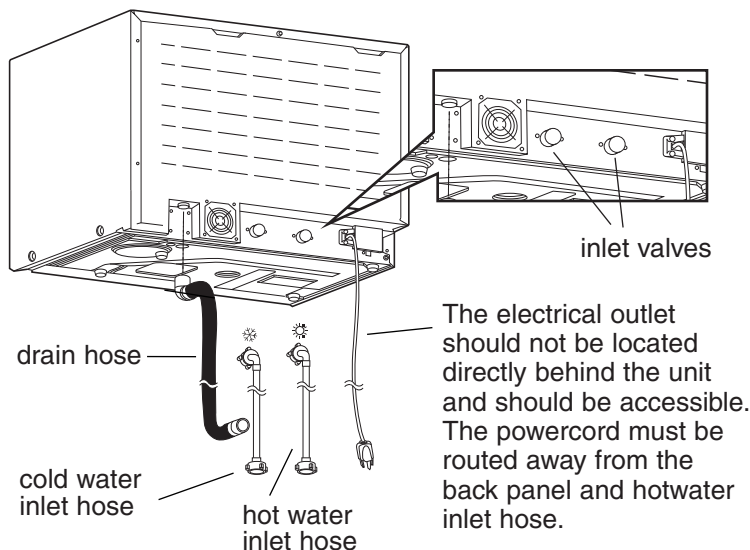

Installation Configurations:

If the Hydrim is installed in a Sterilization Center, the manufacturer of the Sterilization Center should allow a 75 mm/3" space at the top, back and both sides of the Hydrim. This will facilitate installation, leveling, and service access to the Hydrim.

The cabinetry will need to be vented and allow the air exhaust from the dryer to escape. At least 75mm/3" of space should be provided behind the rear panel.

Do not move the Hydrim into place by maneuvering the open wash chamber door. This may cause to door to become misaligned and leak.

Option 1. Cabinet / Sterilization Center

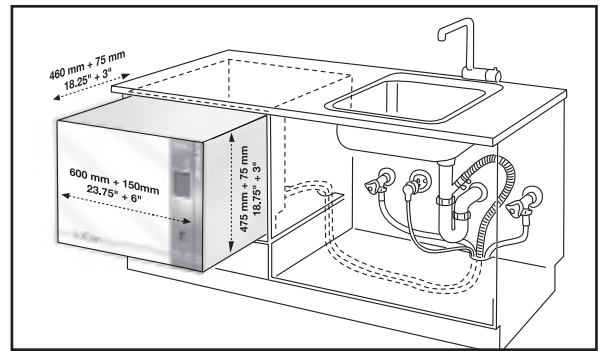

Option 2. Sliding Shelf

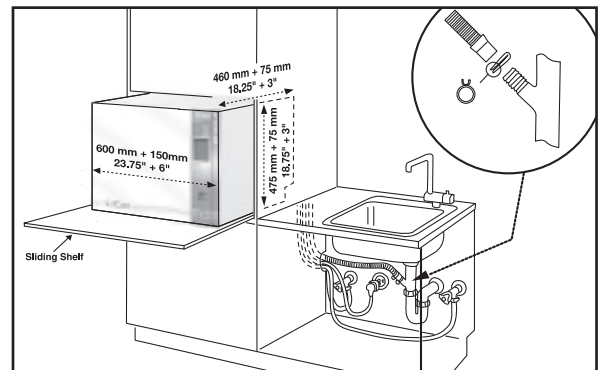

Option 3. Counter Top

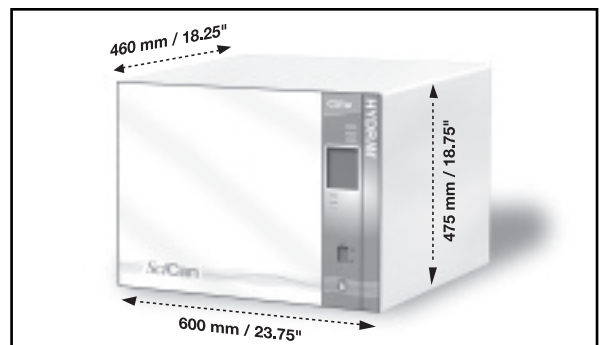

4. Installation Instructions

Connecting the water inlet hoses:

Connect the hot water hose (red) to the hot inlet valve on the Hydrim (indicated by a red dot) and the cold water hose (blue) to the cold water inlet valve on the Hydrim (indicated by a blue dot).

The connector with the elbow should be attached to the back of the Hydrim unit. The washer with the screen goes to the water supply connector. Make sure that the inlet valves are free of debris.

Drain requirements:

Connect the drain hose to the drain outlet. The drain hose can be attached to existing drain lines using a 3.5 cm/1.5" or larger standpipe / P-trap combination. If the hose is connected directly to the drain line, fittings and adapters should not reduce water flow. The drain hose should be attached to the main drain at a point no more than 1 metre above the base of the Hydrim. A floor drain is acceptable (check local codes).

Leveling the Hydrim:

For the unit to function properly, it will need to be correctly leveled. To level the unit, follow these steps:

1. Adjust the legs underneath the unit.
2. Use the leveling bubble on the top right hand side as a guide.
3. When the bubble is in the center, the unit is correctly leveled.

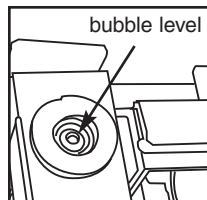

Installing Cleaning Solution:

Ensure that the quick-connect cap on the HIP Cleaning Solution bottle is tight. Install the bottle and loosen the screw-cap slightly to prevent formation of a vacuum.

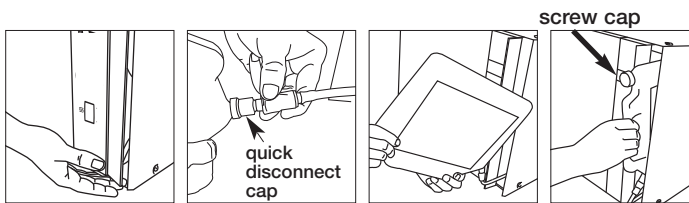

Additional Information:

- The Hydrim unit is heavy (34 kg/75 lbs.). Exercise caution when moving it.
- The Hydrim must be properly grounded.
- The Hydrim is equipped with an air gap / anti-suction device to prevent backflow of dirty water into the water supply. No other air gap device is necessary.
- If you need to extend the water inlet and drain hoses, ensure that you use commercial grade plumbing hose. The maximum length of the drain hose is 3.3 m/13 ft.

Testing water hardness and setting the water softener (salt):

Hydrim is equipped with a built-in water softening system which needs to be adjusted according to the local water hardness. The Hydrim water test kit includes three water hardness test strips in bags. Take a water sample from the location where the machine will be installed. Open one of the bags and remove the test strip. Dip the strip in the water. Compare the color of the strip with the chart on the back of the bag. Determine the water hardness according to the chart on the water test kit envelope. Power the unit on. Touch the "i" in the lower right hand corner of the screen. Select "Setup" and then "Set Regeneration". Using the up and down arrows, set the water softener regeneration level according to this table:

Hardness – ppm	Hydrim setting
0 - 180	0
190 - 400	1
410 - 540	2
550 - 890*	3
> 890	Additional water treatment required

* consider using an additional water treatment

Pour 0.5 litre/1 quart of water into the water softener by pouring it into the salt container and inserting it into the chamber wall. Add 0.5 kg/1 lb. of water softening salt in the same manner. Screw the salt container tightly into the wall of the chamber.

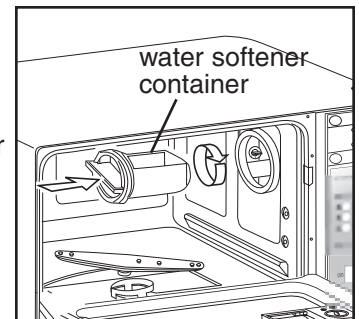

Installation Test:

Turn on the shut-off valves. Run a test cycle, checking for leaks.

5. Instructions for Use

5.1 Instrument Reprocessing Recommendations

The Hydrim C51w is designed to clean general dental and medical instruments.

SciCan recommends terminal sterilization after processing in the Hydrim C51w.

When used correctly, the Hydrim C51w is effective for the removal of debris on instruments that may result in the insulation of microorganisms during terminal sterilization. Prior to placing instruments in the Hydrim, consult the instrument manufacturer's reprocessing instructions.

Examples of medical and dental instruments suitable for cleaning in the Hydrim C51w include:

- Stainless steel scalers, spatulas and hemostats.
- Stainless steel retractors, needle holders, skin hooks, tissue forceps, scissors, curettes, and other stainless steel instruments free of deep cavities.

For best results, instruments processed in the Hydrim C51w should have the following properties:

- Heat resistance to a temperature of up to 70°C / 158°F
- Corrosion resistance in the presence of heat and alkalinity.



Dental handpieces, microkeratomes, phaco tubing, fiberoptics and electrical equipment should not be processed in the Hydrim.



HIP™ (Hydrim Cleaning Solution with Instrument Protection) has been carefully formulated to provide outstanding material compatibility with a wide range of metals and coatings. However, some manufacturers' instruments may not be compatible.



All hinged instruments should be placed in open baskets in Heavy Duty cycle.



When processing small or light objects in the Hydrim use the basket with lid (SciCan part number 01-108294).

5. Instructions for Use

5.2 Cycle Description Chart

	P1 – Rinse and Hold* Cycle	P2 – Regular Cycle	P3 – Heavy Duty Cycle
Description	Use to prevent soil from drying on instruments when they will not be washed within one hour.	Use for moderately soiled loose instruments.	Use for heavily soiled instruments and cassettes
Cold Prewash	<45°C / 113°F	<45°C / 113°F	<45°C / 113°F
Wash	N/A	50°C / 122°F 5 minutes	50°C / 122°F 9 minutes
Rinse	60°C / 140°F	60°C / 140°F	60°C / 140°F
Dry	N/A	1-15 min. (10 min. default)	1-15 min. (10 min. default)
Total Time** without drying	8 minutes	19 minutes	23 minutes
Water Consumption	6 L / 1.59 gallons	17L / 4.5 gallons	17L / 4.5 gallons

* This cycle is not a wash cycle and is not suitable for processing instruments prior to reuse. Always run a wash cycle following the rinse and hold cycle.



** Cycle times depend on the temperature of incoming water.

5. Instructions for Use

5.3 Baskets and Accessories

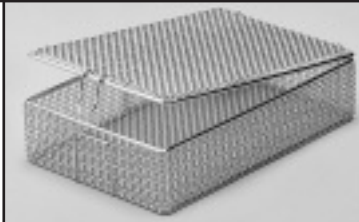
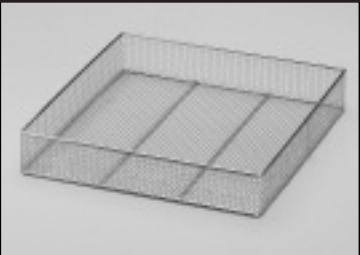
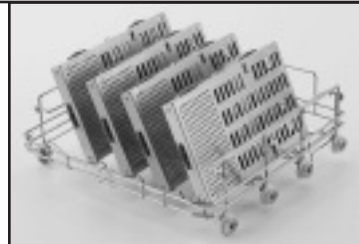
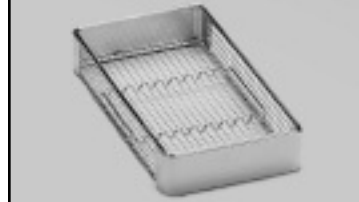

Observe the instrument manufacturer's recommendations for cleaning and care. When loading the unit, arrange loose instruments so that they do not touch one another. Instruments with concave surfaces or cavities should be placed so that water can drain freely.

<h3>1. Baskets only</h3> <table border="1"> <thead> <tr> <th>Part Name</th> <th>Order No.</th> <th>Part Dimensions</th> </tr> </thead> <tbody> <tr> <td>Statim 2000 basket (2 included with Hydrim)</td> <td>01-107240</td> <td>275 mm x 178 mm x 32 mm 10 3/4 x 7 x 1 5/8"</td> </tr> <tr> <td>Statim 5000 basket (Optional)</td> <td>01-107241</td> <td>373 mm x 178 mm x 42 mm 13 1/2 x 7 x 1 5/8"</td> </tr> </tbody> </table>		Part Name	Order No.	Part Dimensions	Statim 2000 basket (2 included with Hydrim)	01-107240	275 mm x 178 mm x 32 mm 10 3/4 x 7 x 1 5/8"	Statim 5000 basket (Optional)	01-107241	373 mm x 178 mm x 42 mm 13 1/2 x 7 x 1 5/8"	
Part Name	Order No.	Part Dimensions									
Statim 2000 basket (2 included with Hydrim)	01-107240	275 mm x 178 mm x 32 mm 10 3/4 x 7 x 1 5/8"									
Statim 5000 basket (Optional)	01-107241	373 mm x 178 mm x 42 mm 13 1/2 x 7 x 1 5/8"									
<h3>2. Basket with hinged lid (optional)</h3> <p>Order No.: 01-108294</p> <p>Dimensions: 216 mm x 140 mm x 54 mm 8 1/2 x 5 1/2 x 2 1/8</p>		<h3>5. Large basket (optional)</h3> <p>Basket Order No.: 01-108210</p> <p>Dimensions: 350 mm x 368 mm x 64 mm 14 1/2 x 13 3/4 x 2 1/2"</p>									
<h3>3. Four cassette rack (optional)</h3> <p>Order No.: 01-109153</p>		<p>Support Rack for Large Basket Order No.: 01-108214</p> <p>Dimensions: 350mm x 350mm x 48mm 13 3/4 x 13 3/4 x 1 7/8"</p>									
<h3>4. Hygiene basket (optional)</h3> <p>Order No.: 01-108298</p> <p>Dimensions: 203mm x 114 mm x 32 mm 8 x 4 1/2 x 1 1/4"</p>		<h3>6. Rack for two baskets and two cassettes (optional)</h3> <p>Order No.: 01-109768S</p>									

5. Instructions for Use

5.4 Activating the Hydrim C51w

Prior to activating the washer-disinfector, check that the water supply is on and follow these steps:

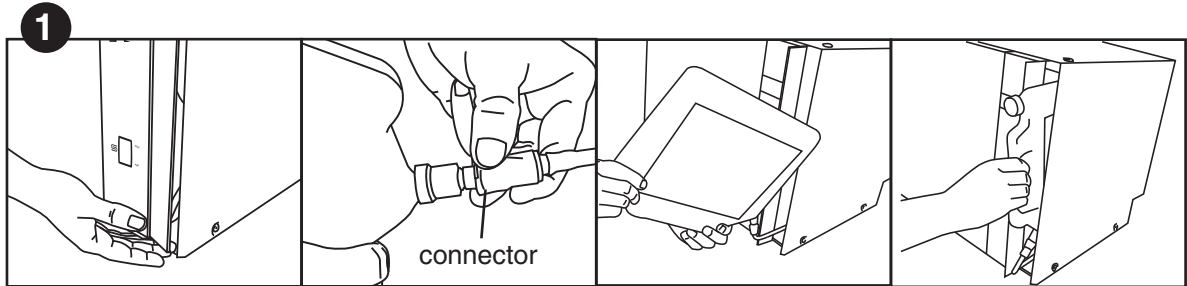

Open the chemical door and ensure that a bottle of HIP Hydrim Cleaning Solution has been installed.



Turn the unit on.



Touch the screen to begin.



Press to unlock door.

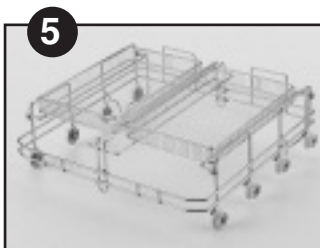

Load instruments into the baskets or cassettes, place them in the machine and close the door.

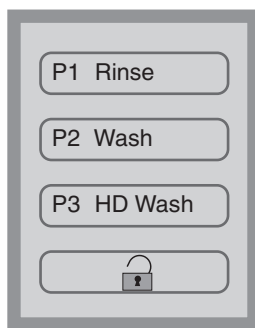

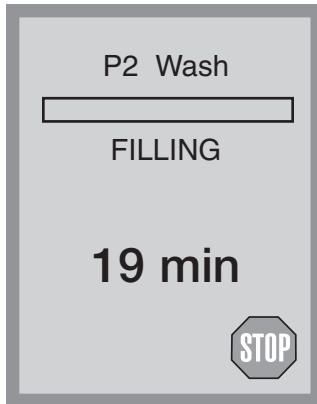

Select the desired cycle. (Use a heavy duty cycle for cassettes, hinged instruments or heavily soiled instruments.)

5. Instructions for Use

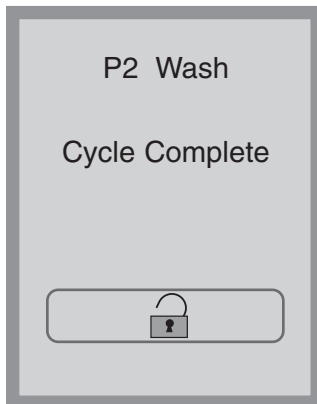

The cycle will start by draining the unit for 20 seconds. The bar on the screen indicates the progression of the cycle. The stage within the cycle is shown beneath the bar (eg. Filling, Rinsing). The estimated time remaining (in minutes) is always displayed. Please note that the time will increase or decrease depending on the projected cycle completion.



When the cycle is complete, the program name and “Cycle Complete” is displayed, and the unit beeps three times. Press  to open the door. Use gloves to unload the instruments. After all cycles, exercise caution as the instruments, trolley, baskets and cassettes may be hot. Inspect the instruments for debris prior to packaging / sterilizing.

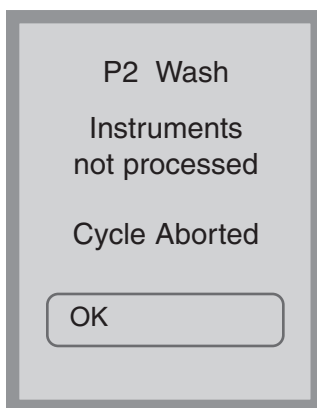

5.5 Interrupting / Aborting a Cycle

The door of the Hydrim is locked during the cycle. If the **STOP** button is pressed, the cycle is aborted and cannot be re-started. The message “Draining. Please wait” will appear. The unit will drain. Then the message “Instruments not processed. Cycle Aborted” will appear. Press OK. Open the door by pressing . Use gloves if handling the instruments. Exercise caution as instruments, trolley, baskets and cassettes may be hot. The cycle must be repeated to ensure that instruments are properly processed. Note that if the drying phase of the cycle is interrupted, the critical parts of the cycle are complete and the message displaying the program name and “Cycle Complete. Drying interrupted” will appear.

5. Instructions for Use

5.6 Overview of Hydrim C51w Menus

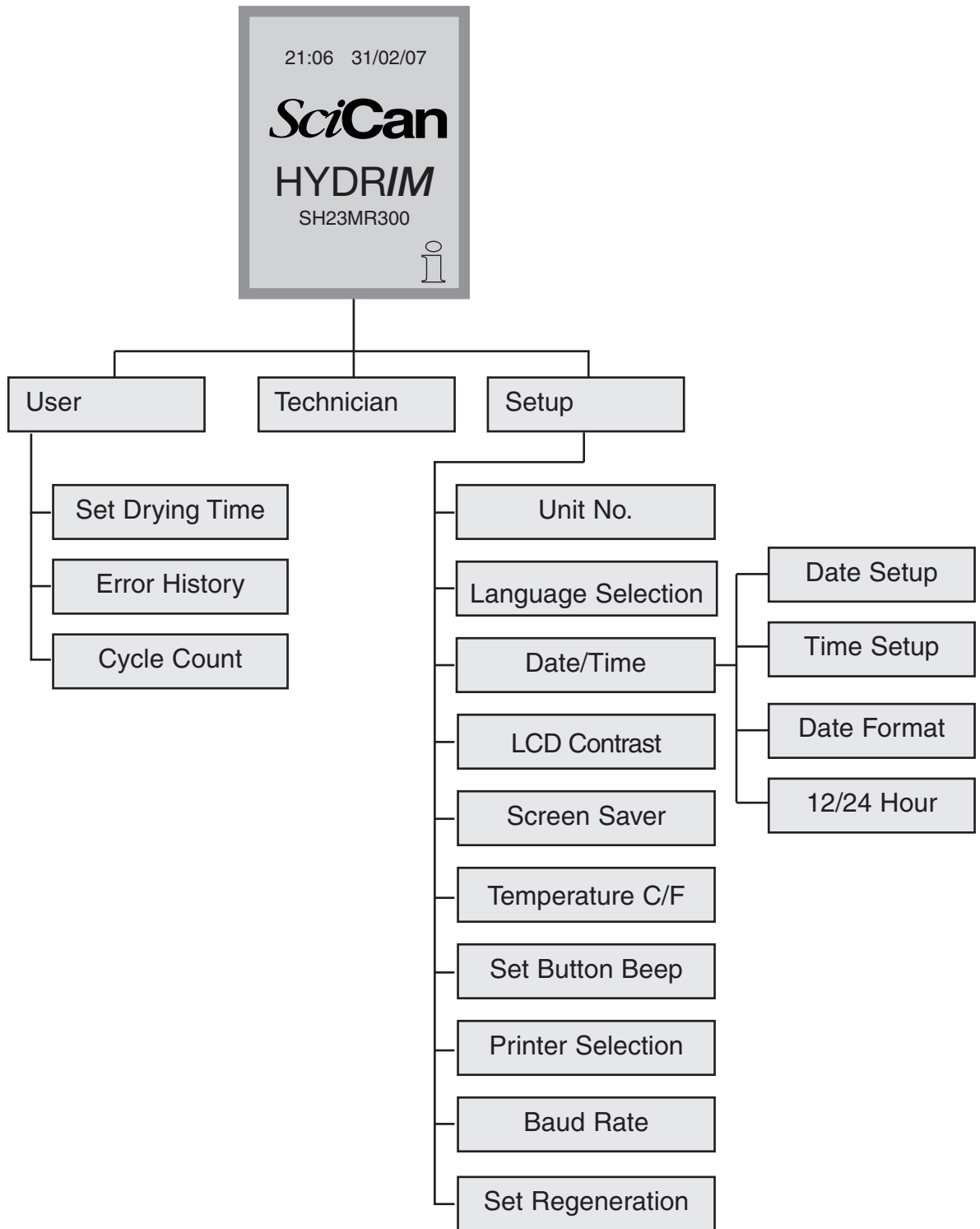

5. Instructions for Use



5.7 User Menu

To access the user menu, follow these steps:

Turn the Hydrim OFF and then ON. An *i* (information) will appear briefly at the bottom right hand of screen.

Touch the *i* to move to the Menu screen.

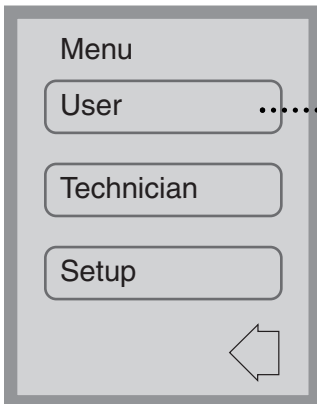

Select User.

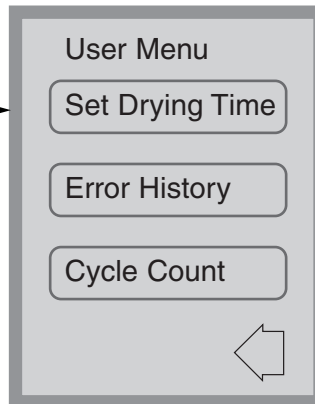

The user menu consists of three choices.

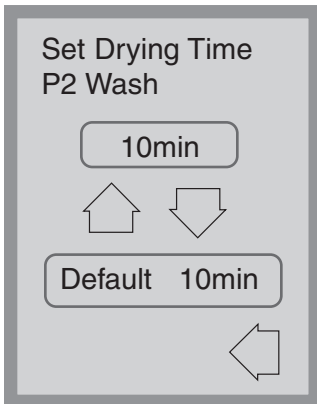

User Menu – Set Drying Time

The drying time for P2 and P3 can be set independently.

Touch the cycle for which you want to set the drying time. Use the up and down arrows to select the desired drying time. Touch *default* if you wish to return to the factory default. Use the back arrow to return to the previous screen.

5. Instructions for Use

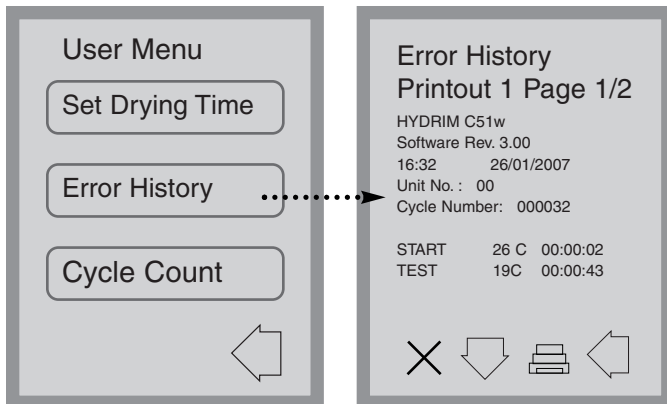

User Menu – Error History

This allows the user to see the last three errors. Press the down arrow to move to the next page / error. If the Hydrim has a printer, press the printer icon to obtain a print-out of the error history. Press the X in the lower left hand corner to clear the error history, except for the last error. Press the back arrow to move to the previous menu.

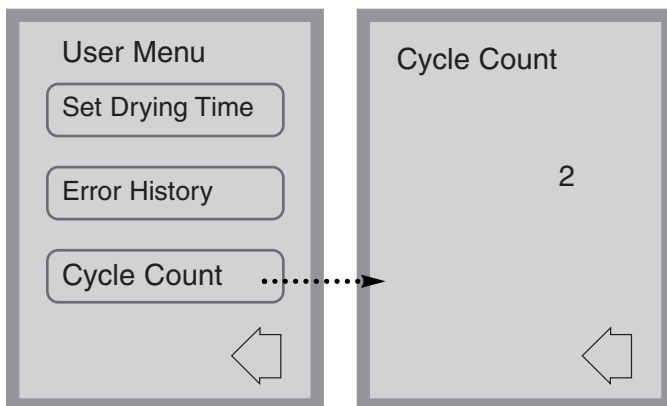

User Menu – Cycle Count

This allows the user to see how many cycles have been run on the Hydrim. Touch cycle count and the number of cycles (completed and aborted) will be displayed. This cannot be reset. Touch the back arrow to return to the previous menu.

5.8 Technician Menu



This menu is only available to authorized technicians.

5. Instructions for Use

5.9 Setup Menu

To access the Setup Menu, proceed to the menu screen by turning the Hydrim OFF and then ON. An i (information) will appear briefly at the bottom right hand corner.



Touch the i to move to the Menu screen and select Setup.

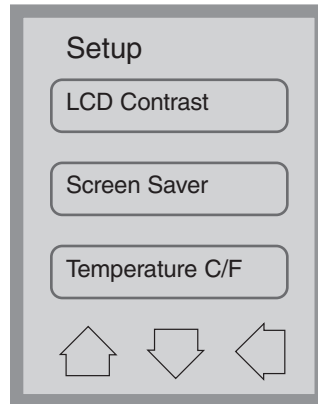
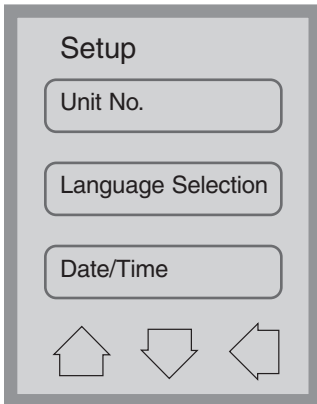

The Setup Menu consists of ten choices as shown. Using the up and down arrows to move through the choices, touch the desired option to select it. For more detail on each setup menu option, refer to the following sections.

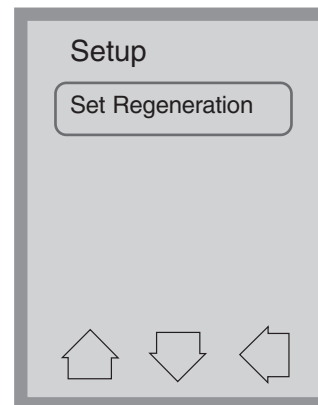
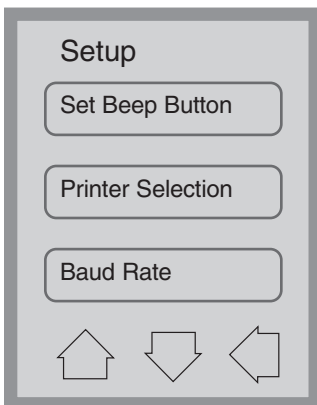

5. Instructions for Use

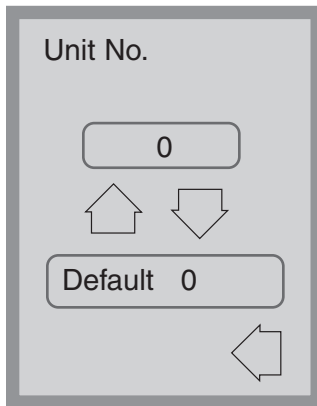

Setup Menu – Unit Number

If you have more than one Hydrim, you can designate them Unit #1, Unit #2, etc. Use the up and down arrow keys to select the unit number. The default is 0.

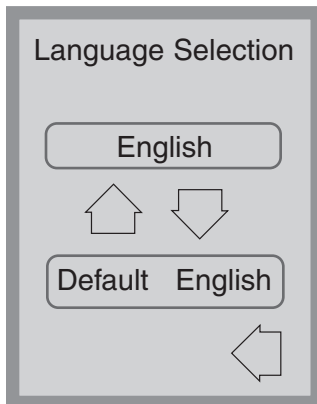

Setup Menu – Language Selection

This allows the user to select among available languages for the Hydrim. Use the up and down arrows to select the desired language. The default language is English. Touch the back arrow to return to the previous menu.

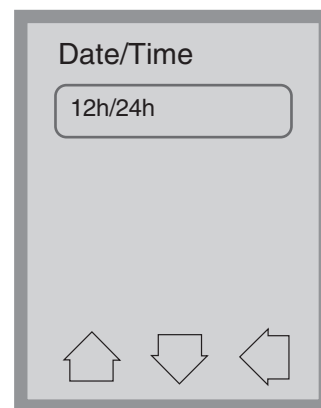
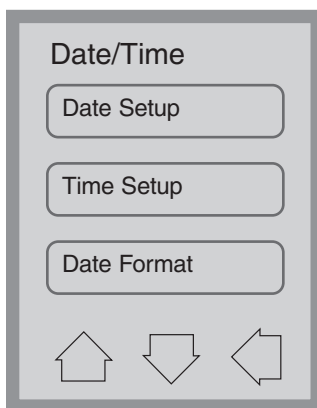

Setup Menu – Date / Time

The Date/Time menu consists of four options as shown. Use the up and down arrows to move from screen to screen. The user can set the current date and time, set the date format and the time format. Touch the desired option and follow the directions below.

5. Instructions for Use



Date Setup

Enter the day, month and year and touch EN to save. Touch CL to clear the last number entered.



Time Setup

Enter the time in hours, minutes and seconds and press EN to save. Touch CL to clear the last number entered.

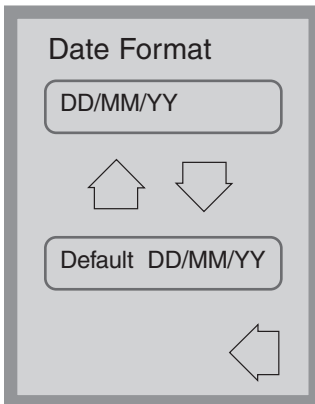

Date Format

Use the up and down arrows to change the date format from DD/MM/YY to MM/DD/YY. The default is DD/MM/YY

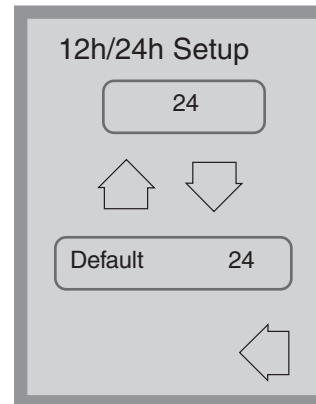

12h/24h

Use the up and down arrows to switch from 12-hour to 24-hour clock. The default is 24-hour clock.

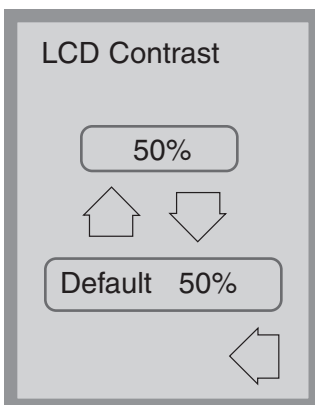

Setup Menu - LCD Contrast

The user can adjust the LCD contrast. Touch the up and down arrows to select the desired contrast. The default is 50%. Touch the back arrow to return to the previous menu.

5. Instructions for Use

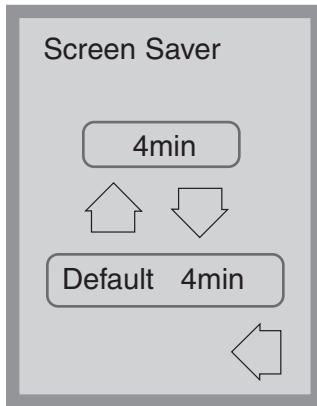

Setup Menu – Screen Saver

The user can adjust the time that elapses before the screen goes into screen saver mode. Touch **Screen Saver**. Touch the up and down arrows to select the desired Screen saver setting. The default is 4 minutes. Touch the back arrow to return to the previous menu.

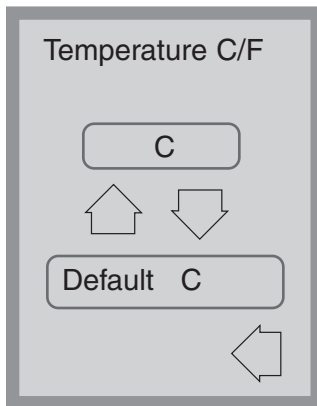

Setup Menu – Temperature C/F

The user can choose to have information displayed in degrees Celsius or degrees Fahrenheit. Touch the up and down arrows to select the desired choice. The default is degrees Celsius. Touch the back arrow to return to the previous menu.

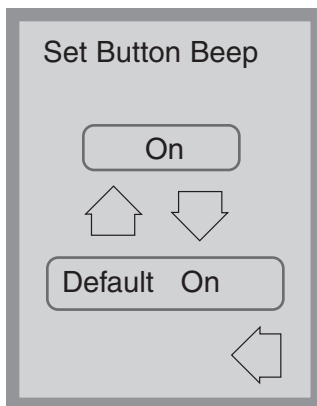

Setup Menu – Set Button Beep

The user can select between having the unit beep or not beep whenever a screen button is touched. Turn the beep on or off by using the up and down arrows. Note that the default setting is ON. Touch the back arrow to return to the previous menu.

5. Instructions for Use

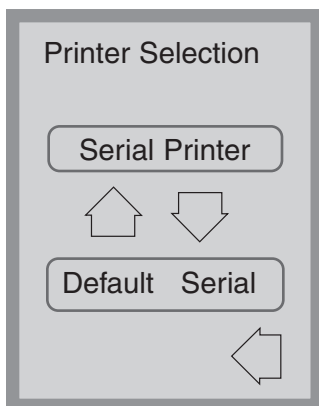

Setup Menu – Printer Selection

Printer selection allows the user to select either a default serial printer or the SciCan Data Logger as the recording medium for cycle information. See section 5.11 for more information.

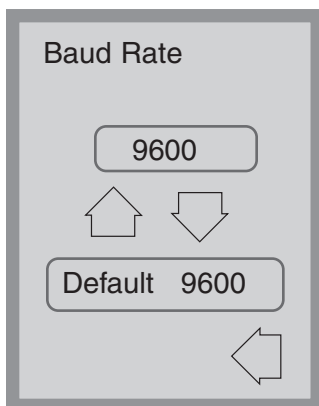

Setup Menu – Baud Rate

The Baud rate is a setting used in conjunction with the Printer Selection. Baud Rate is a measure of how fast data is moving through the serial connection. See section 5.11 for more information.

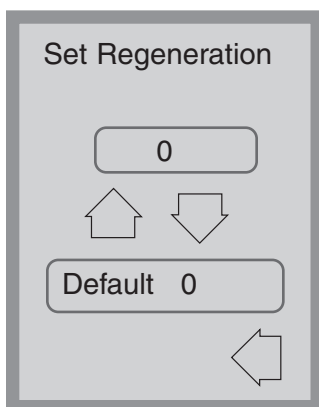

Setup Menu – Set Regeneration

Set the salt regeneration according to the local water hardness. Use the up and down arrows to change the value. The default setting is 0 . See Installation Instructions for further information.

5. Instructions for Use



5.10 Opening the Door in Case of Power Failure

If there is a power failure, open the detergent door and remove the chemical bottle. Keep the chemical bottle upright and ensure that the chemical does not spill. Locate the ring in the top of the detergent compartment and pull it to open the door. Exercise caution! There may be fluid remaining in the unit and the instruments may be hot. Instruments that have not completed the cycle should not be used and should be reprocessed.

5.11 Printer / USB Setup

The Hydrim C51w has an RS-232 port at the back, and can be used with an external printer or the SciCan Data Logger. The printers in the chart below have been tested with the Hydrim. To add or change a printer or SciCan Data Logger, follow these steps:



Turn off the Hydrim and the printer or Data Logger before connecting these devices to the unit.

1. With the printer or Data Logger connected, turn on the Hydrim and press the *i* to move to the Menu screen.
2. In the Setup Menu, select Printer Selection.
3. Select Serial Printer if connecting a printer, or USB Flash/MSD if connecting the SciCan Data Logger. Press the back arrow to return to the Setup Menu.
4. In the Setup Menu, select Baud rate.
5. Select the rate required (refer to chart below for recommended Baud rates). Use the back arrow to return to the Start screen.
6. Ensure that the date and time have been set (see Setup Menu – Date / Time)
7. Now the Hydrim will write its cycle information to the device chosen.

Printer Model	Serial Port Baud Rate
Epson TM-U220D	9600
Citizen IDP-3110-40 RF 115	9600
Star Micro SP212FD42-120	9600
Star Micro SP216FD42-120	9600
Star Micro SP512MD42-R	9600
SciCan Data Logger	Serial Port Baud Rate
For Mass Storage Device	9600

6. Care and Maintenance

6.1 Replacing the HIP Cleaning Solution

The Hydrim C51w uses a 1.9 L / 0.5 gallon container of HIP Cleaning Solution (Part number CS-HIPC). Use only the recommended cleaning solution and read the MSDS before inserting into the unit.



To order additional HIP Cleaning Solution, contact your local dealer. When the message “no detergent” appears on the screen, the cleaning solution container is empty and is in need of changing. To avoid spillage, replace the solution container only when the message appears and be sure to wear gloves.

NOTE: Each cleaning solution container will last approximately 30 cycles.

To replace the cleaning solution container, follow these steps:

1. Turn the power switch OFF.
2. Open the cleaning solution door.
3. Disconnect the cleaning solution connector. Remove any dried chemical by immersing the connector in a cup of water.
4. Remove the empty cleaning solution container and discard or recycle.
5. Connect new container and insert into the cleaning solution compartment. Follow the instructions printed on each cleaning solution container.
6. **Loosen the screw cap** on the bottle slightly to prevent a vacuum forming as the chemical is dispensed.
7. Close the door.
8. Turn the power switch ON

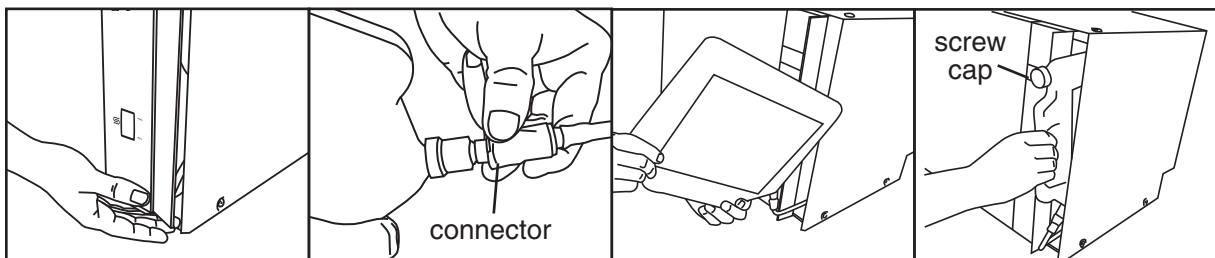

6. Care and Maintenance

6.2 Refilling the Water Softening Salt Reservoir



Check the salt window on the front panel periodically. When the level is low, refill the salt reservoir.

To fill the salt reservoir, follow these steps:

1. Open the salt container lid.
2. Fill the salt container to the top (maximum 0.5 kg/1.1 lb.)
3. Close the salt container lid.
4. Run a complete cycle, with no instruments.



6. Care and Maintenance

6.3 Cleaning the Hydrim C51w

To clean outer surfaces and the decal covering the touchscreen, use a soft cloth moistened with soap and water or a surface disinfectant. Do not use harsh cleaning chemicals.



If preparing the unit for transport or storage, waste water should be removed from the sump.

Waste water in the unit may contain biological contaminants. Use a mechanical means to siphon the contents. Wear disposable rubber gloves. Dispose of absorbent material according to biological waste disposal regulations.

6.4 Filter and Wash Arm Maintenance

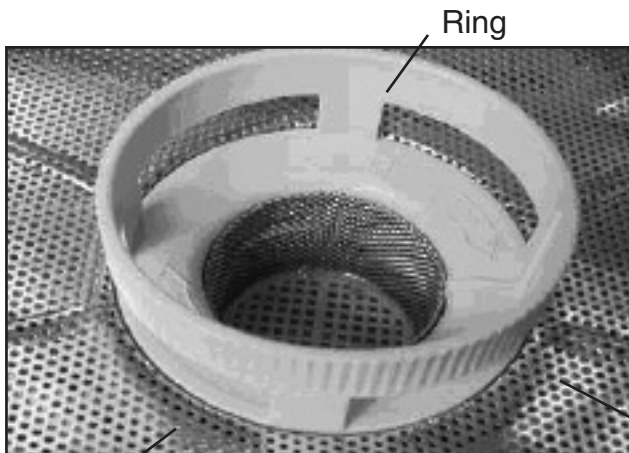

Fine filter – beneath coarse filter

Filter Maintenance:

Inspect the coarse and fine filters in the bottom of the chamber **daily** for debris and clean if necessary. To clean, remove the filter (turn the ring to release it), rinse under a tap and reassemble. Ensure that the filter is firmly locked into position when replaced.

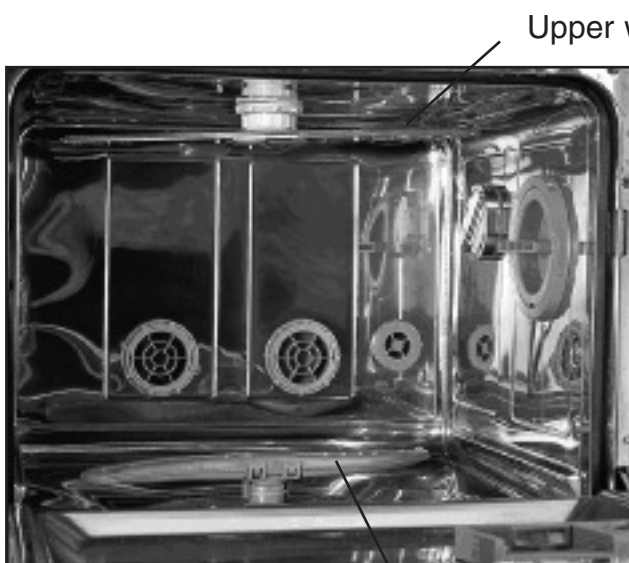

Lower wash arm

Wash Arm Maintenance:

If you see that the wash arms are not turning easily, remove them. To remove the upper arm, unscrew the collar. To remove the lower arm, grasp both ends and pull up. Rinse under a tap and reassemble.

7. Troubleshooting

Problem	Possible Causes and Solutions
Instruments are not clean	<ul style="list-style-type: none"> • Do not overload cassettes or instrument baskets. • Do not load too many cassettes into the Hydrim. • Use the Heavy Duty cycle for cassettes and hinged instruments. • Check filters and wash arms for debris.
Touchscreen / Unit does not come on	<ul style="list-style-type: none"> • Ensure that the power button is turned ON. • Ensure that the plug is properly inserted into the wall socket. • Check if a fuse or circuit is blown – call service for assistance.
The wash arms do not rotate	<ul style="list-style-type: none"> • Remove the wash arms, clean and reinstall them.
The door cannot be opened	<ul style="list-style-type: none"> • The cycle is not complete. • The cycle was aborted and the unit has not completed draining yet.
Operating cycles appear to be taking too long to complete	<ul style="list-style-type: none"> • The water is not hot enough. Check that the incoming hot water temperature is in the recommended range. • Check that the hot and cold hoses are not reversed.
“No detergent” message comes on when there is still chemical left in the container	<ul style="list-style-type: none"> • Check for a kink in chemical tubing. • Loosen the screw cap on the chemical bottle.
Drying Performance is inadequate	<ul style="list-style-type: none"> • Increase the drying time (user menu).
There is a “printing” message at the end of the cycle, but there is no printer attached	<ul style="list-style-type: none"> • In the Setup Menu, Printer / USB setup (section 5.11) ensure that "serial" is selected.
Printer does not print	<ul style="list-style-type: none"> • Check that printer is plugged into both the Hydrim and the electrical outlet. • Check that the printer is ON and has paper • Check that printer and baud rate are set correctly (section 5.11).

NOTE: Fuses should NOT be replaced by the operator. Call an authorized service technician for assistance.

7. Troubleshooting

Error Messages

Error	Cause	Solution
CF1 Water Heating failure	The water does not reach the required temperature in the specified time	Call for service.
CF2 Chamber Filling Failure	The water does not fill the chamber within the specified time.	Check that the water hoses are not kinked. Open the water shut-off valves.
CF3 Chamber temperature reading failure	Faulty sensor.	Call for service.
CF4 Water evacuation failure	Water cannot drain from the unit.	Check that the drain hose is not kinked. Check that the filters in the bottom of the chamber are not obstructed.
CF9 Software or PCB Failure	Cycle length is more than 2hr 30 min.	Call for service.
CF15 Chamber overflow	Overflow switch did not turn off after 30 sec of running the drain pump.	Check if drain is blocked; Call for service.

8. Material Safety Data Sheet

1.0 PRODUCT AND COMPANY IDENTIFICATION

Product Name: HIP – Hydrim Cleaning Solution With Instrument Protection

Product Use: Cleaner

Manufacturer/Supplier: Virox Technologies Inc.

Address: 2815 Bristol Circle, Unit 4, Oakville, Ontario L6H 6X5

Phone #: (905) 813-0110

(W)HMIS Classification: Health: 2 Flammability: 0
Reactivity: 0 Personal Protection: B (Gloves + Goggles)

2.0 INFORMATION ON ACTIVE INGREDIENTS

Ingredient	CAS#	Wt%	OSHA-PEL	ACGIH-TLV
1-Hydroxyethane -1,1-Diphosphonic acid, K salt	2809-21-4	5-10%	N/E	N/E
1, 2 propylene glycol	57-55-6	15-20%	N/E	N/E
Xylenesulfonic acid, K salt	1300-72-7	5-10%	N/E	N/E
N-Octyl -2-Pyrrolidone	2687-94-7	3-5%	N/E	N/E

3.0 HEALTH HAZARD IDENTIFICATION

Rout of Entry: Skin contact, Eye, Ingestion.

Signs and Symptoms

Eye contact: Causes irritation.

Skin contact: Causes irritation.

Ingestion: Like any product not designed to be ingested, this product may cause stomach distress if ingested in large quantities.

Inhalation: Not a normal route of exposure.

Acute overexposure: Corrosive. May cause burn or irritation.

Chronic Overexposure: Prolonged or repeated exposure can cause drying, defatting and dermatitis.

Respiratory Tract
Sensitization: Non-hazardous by WHMIS criteria.

Carcinogenicity: Non-hazardous by WHMIS criteria.

Teratogenicity: Non-hazardous by WHMIS criteria.

Mutagenicity: Non-hazardous by WHMIS criteria.

Reproductive Effects: Non-hazardous by WHMIS criteria.

8. Material Safety Data Sheet

4.0 FIRST AID MEASURES

Eye:	Immediately flush with water for 15 minutes while lifting eyelids and rolling eyes. Get medical attention if irritation develops or persists.
Skin:	Wash promptly with soap and water.
Ingestion:	Get medical help. Do NOT induce vomiting. If conscious and medical help not readily available, give water.
Inhalation:	Not a normal route of exposure. If symptoms develop, move to fresh air. If breathing is difficult get medical attention.

5.0 FIRE FIGHTING MEASURES

Flash point:	Not Available
Auto-Ignition temperature:	Not Available
Extinguisher Media:	Water spray, dry chemical, foam, carbon dioxide.
Special Fire Fighting Procedures:	Firefighters should have eye protection and wear self-contained breathing apparatus.

6.0 SPECIAL PRECAUTIONS AND SPILL/LEAK PROCEDURES

Precautions to be taken in handling and storage:
Store in a cool, dry, well ventilated location.

Other Precautions:
Avoid skin contact. Keep containers tightly closed. No smoking or eating in handling area.

Steps to be taken in case Material is Released or Spilled:
Flush into sewage system in accordance with local regulations.

Waste Disposable Methods:
Review federal, provincial, and local government requirements prior to disposal.

7.0 EXPOSURE CONTROLS/PERSONAL PROTECTION

Gloves:	Natural or butyl rubber, nitrile or neoprene gloves.
Eye Protection:	Safety Glasses.
Respiratory Protection:	Not normally required if good ventilation is maintained and exposure guidelines are not exceeded.
Other protective equipment:	As required by employer code.

8. Material Safety Data Sheet

8.0 PHYSICAL/CHEMICAL CHARACTERISTICS

Physical State: Liquid	Boiling Point: No Data
pH: 9.5-10.5	Specific Gravity: 1.14-1.15@25°C
Solubility in Water: 100% soluble in water.	Appearance and Color: Clear colorless to slight yellow.
Melting Point: No Data	

9.0 PHYSICAL HAZARDS/REACTIVITY DATA

Stability:	Stable under normal conditions of handling, use and transportation.
Incompatibility (Materials to Avoid):	Acids.
Hazardous Decomposition Products:	Combustion produces carbon dioxide and carbon monoxide.
Hazardous polymerization:	Will Not Occur.

10.0 TRANSPORTATION

T.D.G./D.O.T. Classifications:	Not regulated.
--------------------------------	----------------

11.0 REGULATORY INFORMATION

Occupational health and safety Regulations

WHMIS Class:	Class D, Division 2B
OSHA & WHMIS:	MSDS prepared pursuant to the Hazard Communication Standard (CFR29 1910.1200) and Canadian WHMIS regulations (Controlled Products Regulations under the Hazardous Products Act).
Environmental Regulatory Lists:	SARA – Section 313 (Toxic Chemical Release Reporting) 40 CFR 372 : No reportable ingredients.
Toxic Substances Control Act (TSCA):	All ingredients are listed on the Chemical Substances Inventory or exempt.
Canadian Domestic Substance List (DSL):	All ingredients are listed on the DSL or exempt.

12.0 PREPARATION INFORMATION

Date:	November 9, 2005 MSDS
Prepared by:	Virox Technologies Inc.
Telephone:	(905) 813-0110

Disclaimer: Information for this material safety data sheet was obtained from sources considered technically accurate and reliable. While every effort has been made to ensure full disclosure of product hazards, in some cases data is not available and is so stated. Since conditions of actual product use are beyond control of the supplier, it is assumed that users of this material have been fully trained. No warranty, expressed or implied, is made and supplier will not be liable for any losses, injuries or consequential damages which may result from the use of or reliance on any information contained in this form. If user requires independent information on ingredients in this or any other material, we recommend contact with the Canadian Center for Occupational Health and Safety (CCOHS) in Hamilton, Ontario (1-905-877-4400) or the local office of US EPA.

9. Warranty

Limited Warranty

For a period of one year, **SciCan** guarantees that the **Hydrim C51w**, when manufactured in new and unused condition, will not fail during normal service due to defects in material and workmanship that are not due to apparent abuse, misuse, or accident. In the event of failure due to such defects during this period of time, the exclusive remedies shall be repair or replacement, at **SciCan's** option and without charge, of any defective part(s), provided **SciCan** is notified in writing within thirty(30) days of the date of such a failure and further provided that the defective part(s) are returned to **SciCan** prepaid.

This warranty shall be considered to be validated, if the product is accompanied by the original purchase invoice from the authorized **SciCan** dealer, and such invoice identifies the item by serial number and clearly states the date of purchase. No other validation is acceptable. After one year, all **SciCan's** warranties and other duties with respect to the quality of the product shall be conclusively presumed to have been satisfied, all liability therefore shall terminate, and no action or breach for any such warranty or duty may thereafter be commenced against **SciCan**.

Any express warranty not provided hereon and any implied warranty or representation as to performance, and any remedy for breach of contract which, but for this provision, might arise by implication, operation of law, custom of trade or course of dealing, including any implied warranty of merchantability or of fitness for particular purpose with respect to all and any products manufactured by **SciCan** is excluded and disclaimed by **SciCan**.

10. Specifications

Height 475 mm / 18.75"

Width: 600 mm / 23.75"

Depth: 460 mm / 18.25"

Depth with door open: 780 mm / 30.75"

Weight: 35 kg / 75 lbs.

Running Noise: 60 dB(A)

Hot and cold water connections: 3/4" garden hose

Inlet water pressure: 1-10 bar / 14.5-145 psi

Incoming hot water temperature*: 50° to 70°C / 122° to 158°F

Drain: 3/4"

Water softener: 0.5 kg / 1.1 lbs. salt capacity

Drying System: Heater 1 kW

Electrical Connection: 208-240 V 60 Hz 10A (North America)
220-240 V 50 Hz 10 A (International)

Equipment pollution degree: Pollution Degree 2

Equipment installation category: Installation category II

Maximum relative humidity: 80% for temp up to 31°C / 88°F
50% for temp up to 40°C / 104°F

Operating temperature range: -5°C to 40°C / 23°to 104°F

Max. altitude: 2000m / 6561.7 ft.

Mains supply: + / -10% of nominal

Required clearance for ventilation: 75mm / 3" on either side, at the
top and at the rear of the unit.

* If hot water temperature is less than 50°C / 122°F,
and if the power line is 240V, allow 30 minutes between cycles.